

New
Specification



ADVANCED
General Certificate of Education
2018

Centre Number

--	--	--	--	--

Candidate Number

--	--	--	--

Physics

Assessment Unit A2 3B

assessing

Practical Techniques
and Data Analysis

MV18

[APH32]

FRIDAY 11 MAY, MORNING

Time

1 hour, plus your additional time allowance.

Instructions to Candidates

Write your Centre Number and Candidate Number in the spaces provided at the top of this page.

You must answer the questions in the spaces provided.

Do not write on blank pages.

Complete in black ink only.

Answer **all four** questions.

Information for Candidates

The total mark for this paper is 50.

Figures in brackets printed at the end of each question indicate the marks awarded to each question.

You may use an electronic calculator.

- 1 The electrical resistance R of a component may be determined by measuring the potential difference across the component and the current flowing through it. In one experiment, the component was connected across a fixed 4.5V d.c. supply, and an ammeter and a voltmeter were placed in the circuit, as in **Fig. 1.1** below.

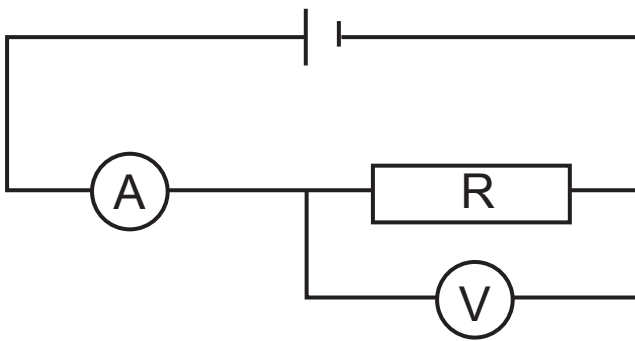

Fig. 1.1

- (a) The analogue voltmeter display is shown in **Fig. 1.2** below. It has a dual scale facility, which means that by connecting across one pair of terminals, the meter reads up to a maximum of 10 volts (the upper scale) and by connecting across the other pair of terminals, the meter reads up to a maximum of 5 volts (the lower scale). The correct scale must be chosen before deciding on the voltage measurement.

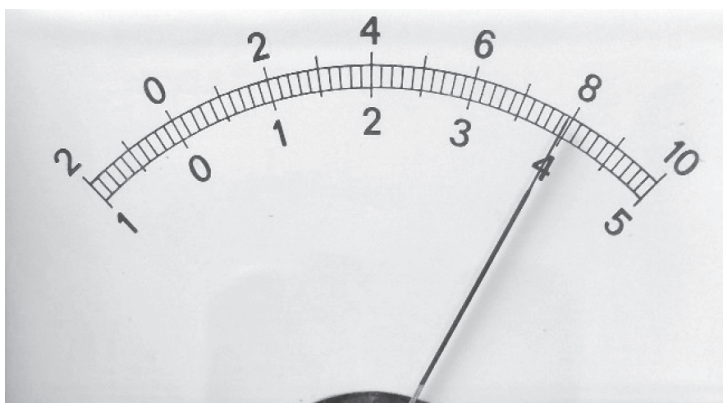

Fig. 1.2

- (i) Using all the information you have been given, decide which scale was being used in this case. Give a reason for your choice. [1 mark]

Scale (10 volt or 5 volt): _____

Reason _____

- (ii) Using the scale you have chosen, state the voltage reading and the absolute uncertainty associated with the reading. [2 marks]

Voltage _____ \pm _____ V

(b) A digital ammeter was used, and it gave a reading of 0.23 amps.

(i) What is the absolute uncertainty associated with this reading? [1 mark]

Uncertainty in current = \pm _____ A

(ii) Use the voltage and current readings to calculate a value for the resistance of the component and the absolute uncertainty in this value. [4 marks]

Resistance = _____ \pm _____ Ω

(iii) Why is it better to refer to an 'uncertainty' rather than an 'error' associated with this reading? [2 marks]

(c) The fixed d.c. supply is replaced with a variable d.c. supply. Explain how you would use this and why it ensures your value for the resistance of the component is both reliable and accurate. [3 marks]

- 2 A pendulum undergoes simple harmonic motion after it has been displaced to one side and allowed to swing freely. A motion sensor is used, so that a graph of displacement s against time t for two complete oscillations can be displayed. An example of such a graph is shown in **Fig. 2.1**.

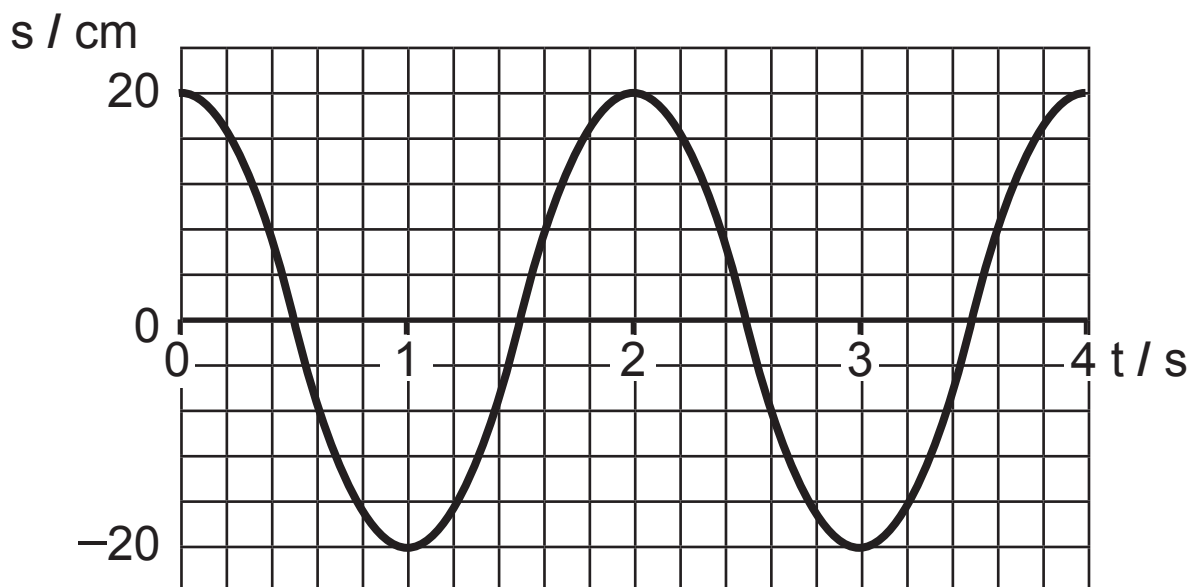

Fig. 2.1

- (a) (i) By finding the gradient of a tangent to the curve, use **Fig. 2.1** to determine the size of the maximum velocity of the pendulum. State one time at which this maximum value of velocity occurs. [3 marks]

Maximum velocity = _____ cm s^{-1}
occurs at _____ s

- (ii) Determine the minimum velocity of the pendulum.
State one time at which this occurs. [2 marks]

Minimum velocity = _____ cm s^{-1}

occurs at _____ s

- (b) The same pendulum is set in motion a second time, with a smaller initial displacement than before.

- (i) On **Fig. 2.1**, sketch the graph of displacement s against time t for this new motion. [2 marks]

- (ii) How will the magnitude of maximum velocity for this second motion of the pendulum compare to the maximum velocity of the original motion shown in **Fig. 2.1**? [1 mark]

- 3 A cathode ray oscilloscope, CRO, is used to measure the frequency of sound waves produced by a vibrating tuning fork. The signal from a microphone is connected across the y-input of the CRO.

Fig. 3.1 shows the display from the CRO screen while the tuning fork is sounding.

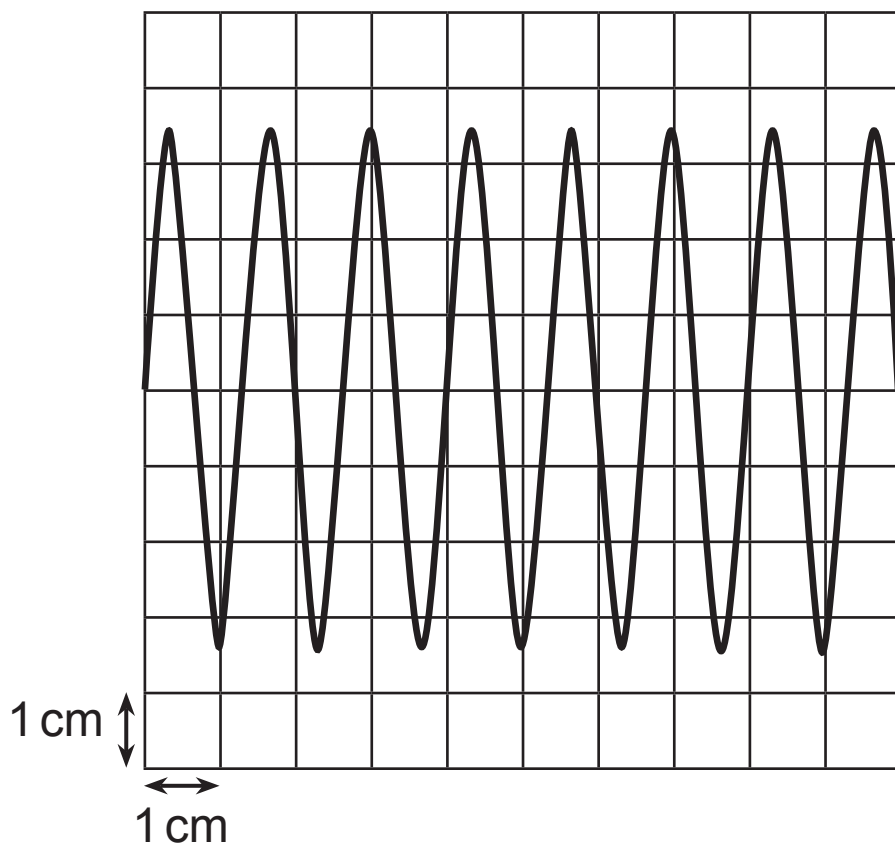

Fig. 3.1

- (i) From the CRO display, determine the frequency of tuning fork being used. The screen is 10 cm wide. The timebase is set to 1.5 ms cm^{-1} . [4 marks]

Frequency = _____ Hz

- (ii) The y-sensitivity is set at 2 mV cm^{-1} . What is the peak voltage of the display? [1 mark]

Voltage = _____ mV

- (iii) How would you expect the display to change over time, as the tuning fork continues to sound? [1 mark]

- (iv) On **Fig. 3.2** sketch the display you would see if the timebase is switched off. [2 marks]

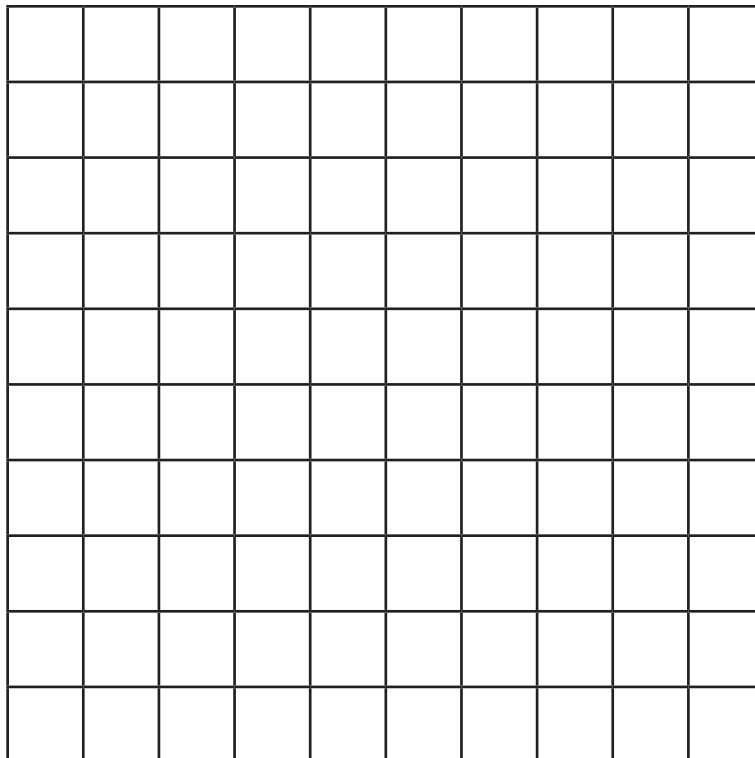

Fig. 3.2

BLANK PAGE

- 4 Geiger and Nuttall proposed a theory relating the half-life $t_{\frac{1}{2}}$ in seconds of an alpha emitting nuclide to the energy E in MeV of the emitted alpha particle. The theory is expressed in **Equation 4.1**.

$$\log_{10} t_{\frac{1}{2}} = AE^{-\frac{1}{2}} - B \quad \text{Equation 4.1}$$

- (a) (i) State what the unit abbreviation MeV stands for.
[1 mark]

- (ii) State the unit of each of the constants A and B in **Equation 4.1**. If they do not have a unit write 'no unit'. [2 marks]

Unit of A = _____

Unit of B = _____

(b) **Table 4.1** gives experimental values of E and $t_{\frac{1}{2}}$ for some alpha emitting nuclides. Values for $E^{-\frac{1}{2}}/\text{MeV}^{-\frac{1}{2}}$ and $\log_{10}(t_{\frac{1}{2}}/\text{s})$ have been calculated.

Table 4.1

Nuclide	E/MeV	$t_{\frac{1}{2}}/\text{s}$	$E^{-\frac{1}{2}}/\text{MeV}^{-\frac{1}{2}}$	$\log_{10}(t_{\frac{1}{2}}/\text{s})$
^{238}U	4.20	1.4×10^{17}	0.488	17.15
^{234}U	4.82	7.7×10^{12}	0.455	12.89
^{228}Th	5.42	6.0×10^7	0.430	7.78
^{208}Rn	6.14	1.5×10^3	0.404	3.18
^{212}Po	7.39	1.8×10^{-3}	0.368	-2.74

(i) Have the values of $E^{-\frac{1}{2}}/\text{MeV}^{-\frac{1}{2}}$ been recorded correctly in **Table 4.1**? Explain your answer.
[1 mark]

- (ii) On the graph grid of **Fig. 4.1** draw a graph of $\log_{10}(t_2^{1/2}/s)$ against $E^{-1/2}/\text{MeV}^{-1/2}$. Scale the axes appropriately, plot the points and draw the best fit line. [6 marks]

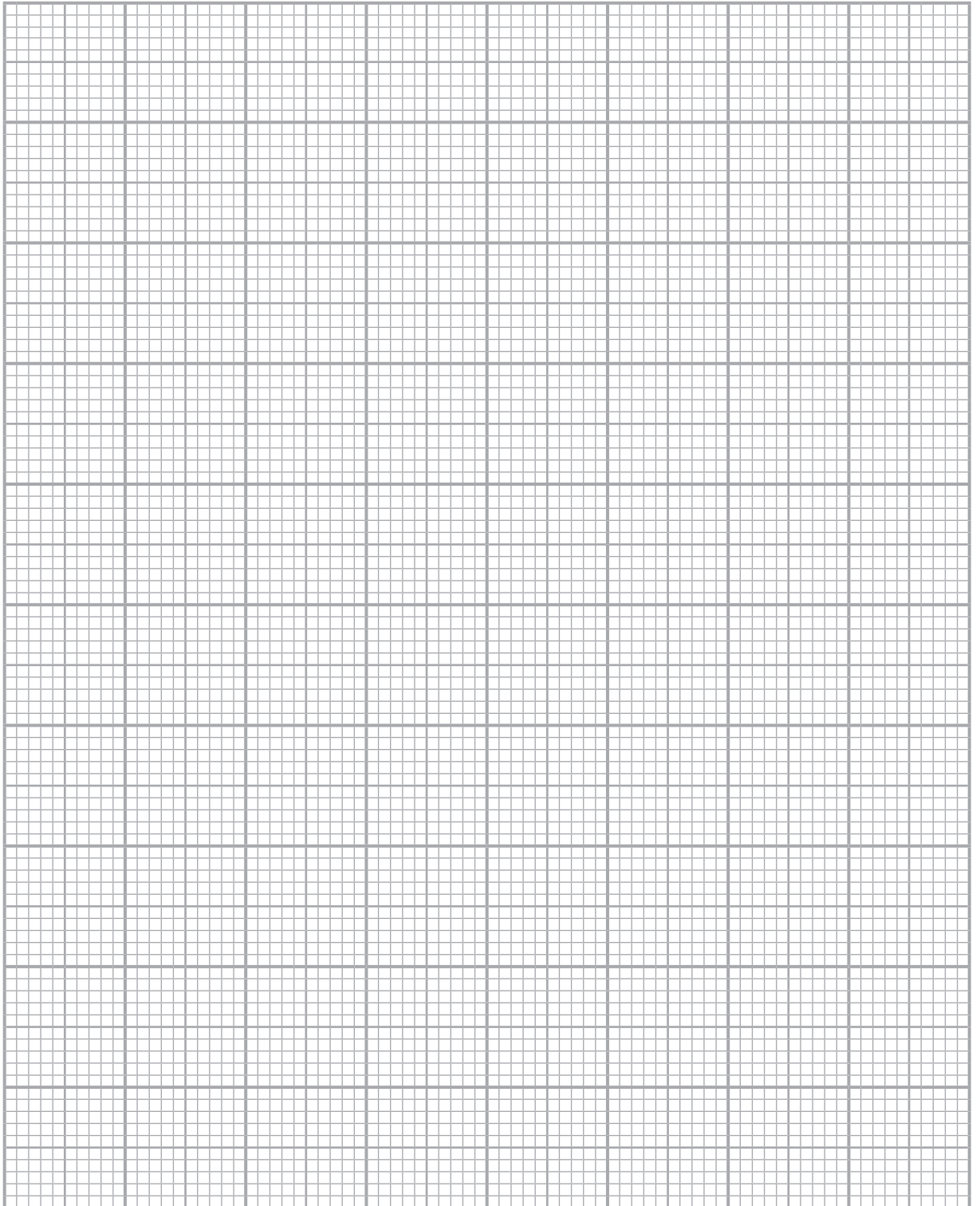

Fig 4. 1

(c) **Table 4.2** gives two values of E .

Table 4.2

E/MeV	$E^{-\frac{1}{2}}/\text{MeV}^{-\frac{1}{2}}$	$\log_{10}(t\frac{1}{2}/\text{s})$
4.53		
7.20		

- (i) Enter the corresponding values for $E^{-\frac{1}{2}}$ in the second column of **Table 4.2**. [2 marks]
- (ii) According to the Geiger and Nuttall proposed theory in **Equation 4.1**, $A = 148$ and $B = 53.5$. Use these values and **Equation 4.1** to calculate the Geiger and Nuttall theoretical values for $\log_{10}(t\frac{1}{2}/\text{s})$.

Enter the values in the third column of **Table 4.2**.
[2 marks]

- (iii) On the graph grid of **Fig. 4.1** (page 13) plot the two theoretical points from **Table 4.2** (page 14) and join the points by a straight line. Label this line GN. This line is a graphical representation of the Geiger–Nuttall law. [2 marks]

- (d) You should find that your line from the experimental results is not in very good agreement with the line GN. The values of A and B do not work well for the nuclides listed.
- (i) Use your graph to determine a numerical value for A which corresponds with the experimental data in **Table 4.1**. [3 marks]

A = _____

- (ii) Determine the percentage difference in the numerical value for A that corresponds to the experimental data in **Table 4.1** and the numerical value of 148 proposed by Geiger and Nuttall. [2 marks]

Percentage difference = _____ %

THIS IS THE END OF THE QUESTION PAPER

SOURCES

Q1(a)Source: © Principal Examiner

For Examiner's use only	
Question Number	Marks
1	
2	
3	
4	
Total Marks	

Examiner Number

Permission to reproduce all copyright material has been applied for.
In some cases, efforts to contact copyright holders may have been unsuccessful and CCEA will be happy to rectify any omissions of acknowledgement in future if notified.